

# Installation Instructions and Service Manual

## **Model 850 Actuator\* for Trailer Brakes**

**8,000 lbs Capacity  
Drum Brake Ready  
Disc Brake Ready**

US Patents: 6,375,211 and 8,342,559



**\*Model 850 - Manufactured  
after March 2012**

### **MODEL 850 ACTUATOR INSTALLATION INSTRUCTIONS**

**IMPORTANT: READ AND UNDERSTAND THE ENTIRE INSTRUCTION/ASSEMBLY PROCEDURE BEFORE INSTALLING YOUR BRAKES AND ACTUATOR.**

The Model 850 works by the “surge” or “push” of the trailer toward the tow vehicle. This automatically synchronizes the trailer brakes with the tow vehicle axle brakes. When the trailer pushes against the tow vehicle, the actuator telescopes together and applies the force to the master cylinder, supplying hydraulic pressure to the brakes. The built in dampening shock absorber retards the telescoping shock against the hitch ball. Low levels of brake fluid will signal the tow vehicle operator to add brake fluid via coupler knocking.

Be sure to comply with regulations for brakes in your state. Brake laws sometimes are minimum standards and you may wish to add additional brakes to your trailer to meet minimum Gross Vehicle Weight Ratings (GVWR). Read your tow vehicle owner’s manual on towing capacity and other towing recommendations before installing brakes or this actuator.

The Model 850 Actuator is completely assembled and ready to bolt into place (Tongue sizes: 3”x3”, 3”x4” & 3”x5”).

1. Bolt the actuator to the tongue-using grade 5 bolts 1/2 inch in diameter, 4 inches long. Lightweight tongues, less than 10 gauge, require spacer tubes inside the tongue for reinforcement. Attachment strength should equal or exceed 1-1/2 times trailer G.V.W.R.
2. Hydraulic brake lines should be installed on the trailer as described in the installation manual supplied with the brakes. Note: Some disc brakes require the use of flexible brake lines at the connection POINT on the brake caliper. Follow brake manufacturer instructions.
3. Use only DOT-3 brake fluid in the Model 800 actuator. Use a pressure type brake bleeder to bleed brakes. (This type of brake bleeder is available at your local automotive jobber.) Follow manufacturer’s directions. Or, manually bleed the brakes using a heavy-duty flat blade screwdriver inserted in the hole provided on top of the actuator near the front. Insert the screwdriver and use a pumping action to activate the master cylinder in order to bleed the brakes. See page 8 for more details.

To bleed master cylinder and brakes, install bleeder hose on first wheel cylinder to be bled; if tandem axle trailer, bleed closest axle first, and the closest brake on that axle first. Use a loose end of hose from the bleeder valve submerged in a glass container of brake fluid to observe bubbling (hose must be submerged into clean brake fluid to keep air from traveling back into the brake cylinder). Loosen the bleeder screw located in the wheel cylinder one turn, the system is now open to the atmosphere. The bleeding operation for that brake is complete when bubbling stops. Be sure to tighten bleeder screw securely. Each wheel cylinder must be bled until all air is out of the lines. Replenish the brake fluid during the bleeding process so the level does not fall below half full level in the master cylinder reservoir. When bleeding and testing is completed, make sure master cylinder is filled to approximately 3/8” below the top of the reservoir and filler cap is securely in place.

Instruction #08163

**TIE DOWN ENGINEERING • 255 Villanova Drive SW • Atlanta, GA 30336**  
**www.tiedown.com (404) 344-0000 Fax (404) 349-0401**

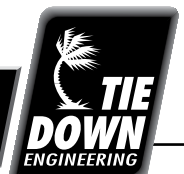

053113.C1251

4. Check with your state motor vehicle department for laws concerning minimum trailer brake requirements. Some states may require brakes on all axles.
5. Road test trailer a short distance to activate the actuator several times. This will fill the reservoir of the master cylinders shock dampening system. Check fluid level again. Remember, low brake fluid levels will result in hitch ball knocking.
6. When testing is completed, make sure master cylinder is filled to approximately 3/8" below the top of the reservoir and filler cap is securely in place. Road test again to make sure brakes work properly.

**RATED CAPACITY: Maximum Actuator Capacity: 8500 lbs. Gross Load, 850 lbs. Maximum Tongue Load, 425 lbs minimum tongue weight.**

The actual in-service rating is limited to that of the ball and hitch being used or the trailer manufacturer's G.V.W.R. shown on the certification label, whichever is lower (Note: GVWR is the Gross Vehicle Weight Rating which includes the trailer and the load weight as a Total Gross Weight).

#### HITCHING TRAILER

1. The vehicle, towing hitch and ball must have a rating equal to or greater than trailer GVWR.
2. Model 800 will accept 2" trailer hitch balls with a 8000# capacity. Trailer balls larger than 2.00" or out of round will not fit the coupler or may result in coupler failure. Balls smaller than 1.970" can cause shock loading and sudden disconnection. Make certain ball latch is in correct position to retain the hitch ball. Push latch lever back until safety latch engages plate below lever latch. Always insert safety pin into forward hole as a safety lock for the hitch ball coupler prior to towing. Do not tow trailer if coupler is damaged.
3. Connect safety cables or chains using crossed pattern under tongue, or follow trailer manufacturer's directions.
4. Connect actuator breakaway cable S-hook to the tow vehicle only. Do not connect S-hook to the safety cables or chains.
5. The breakaway system is designed to only operate after the trailer detaches from the tow vehicle and the safety cable/chains have failed. The breakaway is not a parking brake. Do not use as such.
6. If the breakaway is accidentally applied while un-hitching, insert a flat bladed screwdriver into the spring clip slotted hole under the actuator and pry down to release.
7. Any control devices that restrict operation of the actuator cannot be used. This includes certain sway control devices. The actuator must be free to telescope in response to braking requirements.
8. Equalizing or weight distributing hitches may be used, allow six to eight inches free chain length.  
DANGER: Tongue weight outside rating limits will interfere with performance of actuator, and braking system, and the tow vehicle.
9. The actuator is designed for use with Free-Backing trailer brakes. To block braking action, (in order to back up) with other types of brakes, use an electric solenoid. For reverse trailer movement when braking is are not required, place the safety pin in the upper hole on the side of the actuator to block movement of the actuator. DANGER: Failure to remove pin will also prevent forward braking. Pin must be in the lower, forward coupler hole as a safety lock for the hitch ball coupler latch when towing at all times.

#### MAINTENANCE

1. Always check the brake fluid reservoir before using trailer. Make sure it is at least half full. If not, re-fill to approx. 3/8 inch below the top of the reservoir with DOT 3 brake fluid. Check for leaks and repair as required. Never reuse brake fluid.
2. The model 800 is equipped with two "Super Lube" pins to provide grease to the inner rollers. Use a grease gun to lubricate the rollers through the grease fittings provided, every 6 months. For heavy use, grease every 3 months.
3. To extend coupler and ball life, coat both with a thin coating of grease. This will also eliminate squeaking. Wipe clean and renew grease film each time trailer is used.
4. Examine the actuator for bent parts or wear each time the trailer is used. Replace parts as necessary.
5. There are no user adjustments on the actuator.
6. Actuator travel (shown by coupler roller path) over one inch indicates a need to adjust the brakes or add fluid to the reservoir or a need to bleed the brakes and check connections for leaks. Adjust per instructions found in brake installation manual. In general, back-off the adjusters on drum brakes from locked position, as required. Adjust Free-Backing brakes by rotating wheel in forward direction only. Failure to adjust may result in loss of braking. Disc brakes do not require adjustment, check for pad wear periodically.

7. While towing, if the actuator appears to be knocking against the hitch ball while starting or stopping, check brake fluid reservoir and fill if below 3/8" full from the top. Dampening shock absorber requires sufficient brake fluid in order to retard movement of coupler against hitch ball during towing.

### **WARNING - DISC BRAKE USE**

**Actuator models designed for disc brakes do not have a "check valve" installed. Check valves are required for use with drum brakes. DO NOT USE ANY ACTUATOR DESIGNED FOR DRUM BRAKES ON A TRAILER WITH DISC BRAKES INSTALLED.**

### **WARNING**

Actuator and brakes should always be flushed with fresh water after using trailer in corrosive conditions. This includes salt water, fertilizers and other corrosive materials. Before storing trailer remove brakes and clean thoroughly. It is also wise to repack the bearings at the same time. Failure to properly and adequately maintain the actuator could cause serious damage, injury or death.

### **WARNING**

The breakaway system is not designed to operate if the trailer does not separate completely from the tow vehicle, or if the tongue goes under the rear of the tow vehicle.

### **WARNING**

In the event that the breakaway system is used, check all system components (cable, S-hooks, etc.) for proper working order. Replace any damaged parts with genuine Tie Down parts only.

### **WARNING**

When re-setting the break away system keep hands and fingers clear as you re-set the mechanism, hydraulic pressure held in the system may cause the assembly to snap back suddenly.

### **WARNING**

AVOID sharp turns, which can cause the actuator to bind or jackknife against the tow vehicle or cause a bend in the tongue. Either can damage the actuator causing brake failure. AVOID towing trailer across large bumps or dips that may over stress the connection between the trailer and tow vehicle, as this could result in damage to the actuator.

### **WARNING**

DO NOT REUSE BRAKE FLUID. Always use fresh DOT 3 brake fluid from a fresh container. Failure to maintain proper levels of fluid in the reservoir will cause brake failure.

### **WARNING**

Failure to install the hitch pin before towing can result in accidental opening of the coupler hitch latch which can lead to the trailer coming off of the hitch ball causing serious damage, injury or death. If pin will not fit into the front lower hole, the coupler is not attached properly. Re-set coupler on hitch ball.

### **WARNING**

A minimum of 5% tongue weight and a maximum 10% tongue weight of the trailer GVWR must be positioned over the hitch ball. The Trailer tongue should be parallel to the ground. Too much weight can cause premature brake actuation and loss of control of the towing vehicle. Too little tongue weight can cause the trailer to fishtail, resulting in loss of control of the tow vehicle and trailer (total trailer weight GVWR includes weight of the trailer plus load).

### **WARNING**

A loose fit between the coupler and hitch ball can cause the actuator and hitch ball to separate, causing serious damage, injury or death. Check coupler every time prior to towing and at each stop on long trips. Always make certain that coupler latch safety pin is securely installed into coupler latch.

### **WARNING**

*Brake laws sometimes are minimum standards and you may wish to add additional brakes to your trailer. Read your tow vehicles owner's manual on towing capacity and other towing recommendations before installing brakes or this actuator.*

### **WARNING**

**NEVER ALLOW THE COUPLER LATCH SAFETY PIN TO REMAIN IN THE REVERSE LOCKOUT POSITION HOLE. AFTER REVERSE MANEUVERING, ALWAYS INSERT COUPLER LATCH SAFETY PIN BACK INTO COUPLER LATCH. FAILURE TO REMOVE SAFETY PIN FROM REVERSE LOCK OUT POSITION HOLE WILL PREVENT FORWARD MOVEMENT BREAKING WHICH CAN RESULT IN SERIOUS PROPERTY DAMAGE, INJURY OR DEATH.**

# Model 850\* Actuator

## 8,500 lbs Capacity

### Disc Brake Part Detail

*\*Model 850 - Manufactured  
after March 2012*

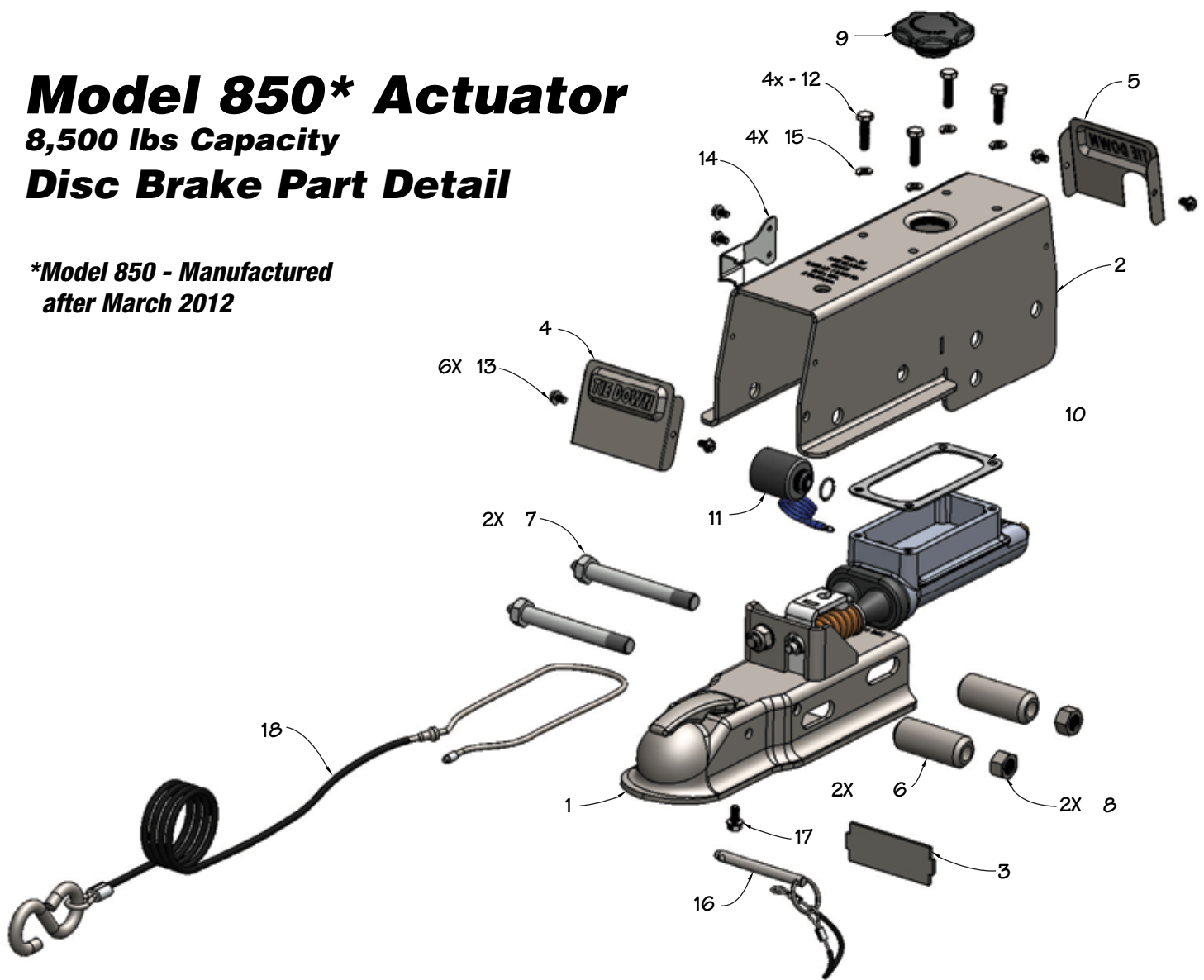

ITEM NO.	QTY.	PART NUMBER	DESCRIPTION
1	1	70461	COUPLER AND MASTER CYLINDER ASSY.
2	1	70466-1	2012 MODEL 80 FORMED ACTUATOR HOUSING
3	1	70462-2	2012 MODEL ACTUATOR HOUSING BRIDGE PLATE
4	1	70462-3	2012 FRONT COVER PLATE
5	1	70462-4	2012 REAR COVER PLATE
6	2	47245	ROLLER FOR 17018 6600LB ACTUATOR
7	2	47246	1/2-20NF x 4" L BOLT
8	2	10661	NUTLOCK REVERSE 1/2-20 ZINC
9	1	70470-4	MOLDED MASTER CYLINDER CAP
10	1	70470-3	MASTER CYLINDER PAPER GASKET
11	1	11286	VALVE SOLENOID 2WNC OPTIONAL BACK FLOW
12	4	10518	BOLT HHCS 1/4-20 x 3/4 GR 5 - ZINC
13	6	10548	10-32 HEX WASHER HEAD THREAD ROLLING SCREW - ZINC
14	1	48844	SAFETY CABLE SPRING
15	4	10554	1/4" SPRING LOCK WASHER - ZINC
16	1	50301	SAFETY PIN & CABLE
17	1	10503	SCREW, 1/4-20 x 1/2" SELF TAP
18	1	50317	66, 70 & 80 E-STOP CABLE ASSEMBLY

# Model 85 Actuator

## 8,500 lbs Capacity

### Drum Brake Part Detail

**\*Model 850 - Manufactured  
after March 2012**

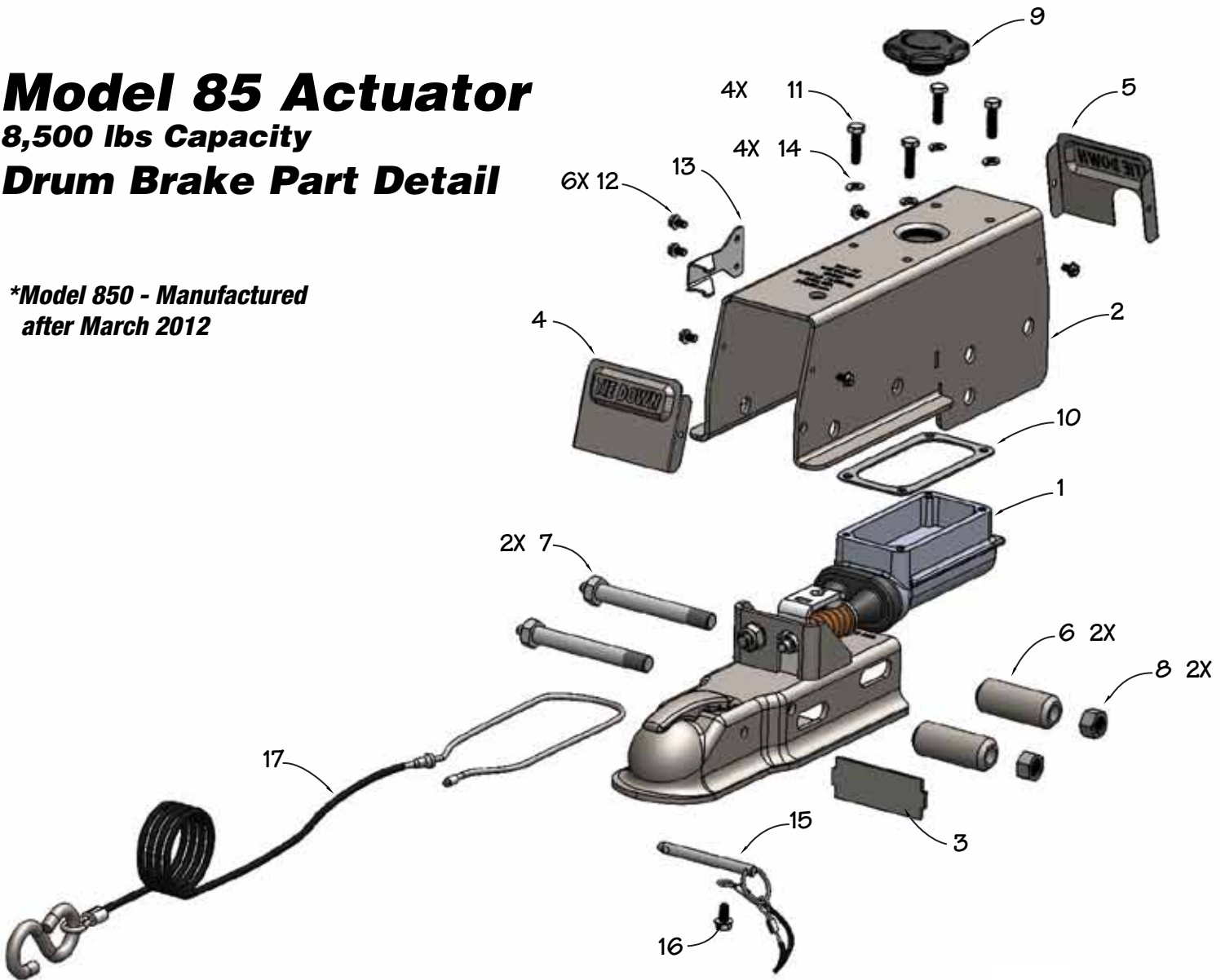

ITEM NO.	QTY.	PART NUMBER	DESCRIPTION
1	1	70461D	COUPLER AND MASTER CYLINDER ASSY.
2	1	70466-1	2012 MODEL 80 FORMED ACTUATOR HOUSING
3	1	70462-2	2012 MODEL ACTUATOR HOUSING BRIDGE PLATE
4	1	70462-3	2012 MODEL FRONT COVER PLATE
5	1	70462-4	2012 MODEL REAR COVER PLATE
6	2	47245	ROLLER FOR 17018 ACTUATOR
7	2	47246	1/2-20NF x 4" L BOLT
8	2	10661	NUTLOCK REVERSE 1/2-20 ZINC
9	1	70470-4	MOLDED MASTER CYLINDER CAP
10	1	70470-3	MASTER CYLINDER PAPER GASKET
11	4	10518	BOLT HHCS 1/4-20 x 3/4 GR 5 - ZINC
12	6	10548	10-32 HEX WASHER HEAD THREAD ROLLING SCREW - ZINC
13	1	48844	SAFETY CABLE SPRING
14	4	10554	1/4" SPRING LOCK WASHER - ZINC
15	1	50301	SAFETY PIN & CABLE
16	1	10503	SCREW, 1/4-20 x 1/2" SELF TAP
17	1	50317	66, 70 & 80 E-STOP CABLE ASSEMBLY

## **TIE DOWN ENGINEERING LIMITED WARRANTY**

Limited Warranty TIE DOWN ENGINEERING Inc ("TIE DOWN") warrants its products to be free from defects in material and workmanship for one year from date of delivery to the original purchaser when properly installed, used and maintained by the purchaser.

This warranty does not apply to damage or loss caused by any or all of the following circumstances or conditions:

- Damage caused during installation.
- Parts, accessories, materials or components used with or replacing any TIE DOWN braking system not obtained from or approved in writing by TIE DOWN.
- Misapplication, misuse and failure to follow the directions or observe cautions and warnings on installation, operation, application, inspection or maintenance specified in any TIE DOWN quotation, acknowledgement, sales literature, specification sheet or installation instruction and service manual ("applicable literature").
- Use of product in any other application other than those described in TIE DOWN's product information materials.

If any TIE DOWN products are found upon TIE DOWN's examination to have been defective when supplied, TIE DOWN will either: credit the purchaser's account for the purchase price of the TIE DOWN product; replace the TIE DOWN product; or repair the product. TIE DOWN has sole discretion in choosing which option to provide. For this LIMITED WARRANTY to apply, TIE DOWN must receive notice of the alleged defect within 30 days of either the discovery of the alleged defect or the expiration of the warranty period, whichever is earlier. Any claim not made within this period shall conclusively be deemed waived.

If requested by TIE DOWN, purchaser shall return the alleged defective product to TIE DOWN for examination at purchaser's expense. TIE DOWN will not pay for expenses incurred in returning a product to TIE DOWN without TIE DOWN's prior written authority. TIE DOWN shall not be liable for any other expenses purchaser incurs to remedy any defect. Purchasers waive subrogations on all claims under any insurance.

**Limitation of Liability:** It is expressly agreed that the liability of TIE DOWN is limited and TIE DOWN does not function as an insurer. THE REMEDIES SET FORTH IN THIS WARRANTY SHALL CONSTITUTE THE EXCLUSIVE REMEDIES AVAILABLE TO THE PURCHASER OR USER AND ARE IN LIEU OF ALL OTHER REMEDIES, EXPRESS OR IMPLIED. THE LIABILITY OF TIE DOWN, WHETHER IN CONTRACT, IN TORT, UNDER ANY WARRANTY OR OTHERWISE, SHALL NOT EXCEED THE PURCHASE PRICE OF THE PARTICULAR PRODUCT MANUFACTURED, SOLD OR SUPPLIED BY TIE DOWN.

**To Obtain Technical Assistance:** To enable TIE DOWN to respond to a request for assistance or evaluation of customer or user operating difficulty, please provide at a minimum the following information by calling 404-344-0000:

- Model number, serial number and all other data on the specific component which appears to be involved in the difficulty.
- The date and from whom you purchased your TIE DOWN product.
- State your difficulty, being sure to mention at least the following: Application, Nature of load involved, and Weight of the load.

**Field Service** If field service at the request of the purchaser is rendered and the difficulty is found not to be with TIE DOWN's product, the purchaser shall pay the time and expense (at the prevailing rate at the time of service) of seller's field representative(s). Charges for service, labor and other expenses that have been incurred by the purchaser, its customer or agent without prior written authorization of TIE DOWN will not be accepted.

**TIE DOWN EXTENDS NO WARRANTY, EXPRESS OR IMPLIED, ON PRODUCTS NOT MANUFACTURED BY TIE DOWN OR TO TIE DOWN'S DESIGN SPECIFICATION, INCLUDING BUT NOT LIMITED TO SUCH ITEMS AS TIRES, BRAKES, BEARINGS, HOSE AND TUBING. PURCHASER'S RECOURSE SHALL BE LIMITED TO ANY WARRANTY OF THE RESPECTIVE MANUFACTURERS.**

**TIE DOWN ENGINEERING • 255 Villanova Drive SW • Atlanta, GA 30336  
www.tiedown.com (404) 344-0000 Fax (404) 349-0401**

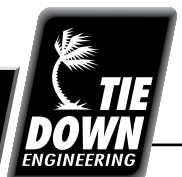

**THIS WARRANTY EXCLUDES ALL IMPLIED WARRANTIES OF MERCHANTABILITY OR FITNESS FOR A PARTICULAR PURPOSE OR ANY PURPOSE.**

THIS WARRANTY DOES NOT COVER NOR EXTEND TO INCIDENTAL OR CONSEQUENTIAL DAMAGE. Some states do not allow the exclusion or limitation of incidental or consequential damages, so the above limitation or exclusion may not apply to you. This warranty gives you specific legal rights, and you may also have other rights which vary from state to state.

No representative has authority to make any representation, promise or agreement except as stated in this Limited Warranty. TIE DOWN reserves the right to make design and other changes upon its products without any obligation to install the same on an previously sold or delivered products.

DUE TO THE WIDE VARIATION IN USES TO WHICH TIE DOWN PRODUCTS (WHEELS, HUBS, BRAKES, ETC.) ARE SUBJECTED BY USERS, WE ARE UNABLE TO SPECIFY CARRYING CAPACITIES OR SPEEDS FOR A PARTICULAR APPLICATION. THEREFORE, THE MANUFACTURER MUST TEST HIS EQUIPMENT UNDER THE MOST SEVERE CONDITIONS TO DETERMINE THAT TIE DOWN PRODUCTS ARE SUITABLE.

THERE ARE NO WARRANTIES WHICH EXTEND BEYOND THOSE DESCRIBED ABOVE. EFFECTIVE JANUARY 2001 THIS WARRANTY SUPERSEDES ALL PRIOR WARRANTIES, WRITTEN OR IMPLIED.

## Drill Template

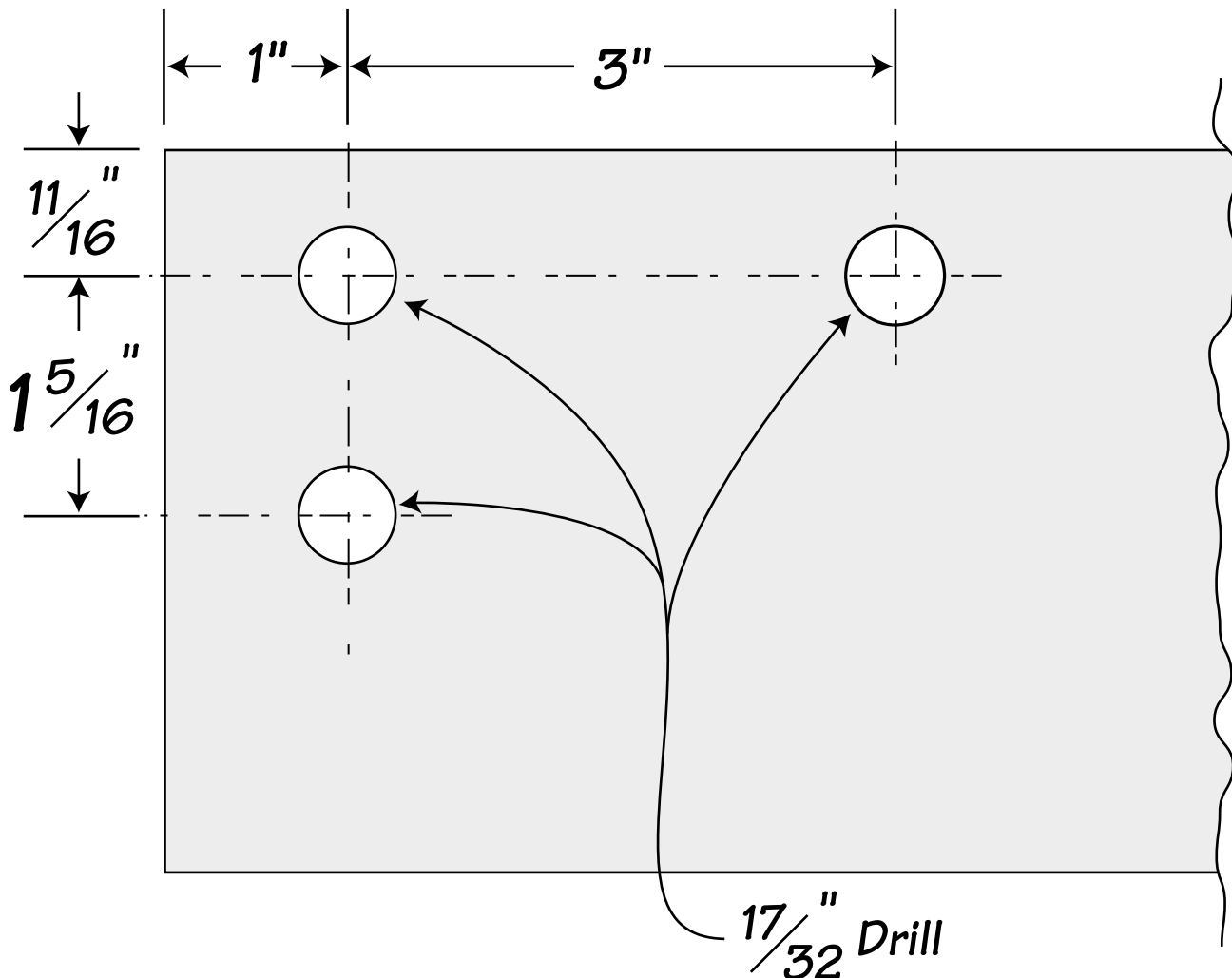

# Instructions for Bleeding Tie Downs Model 660, 750 & 850 Actuators

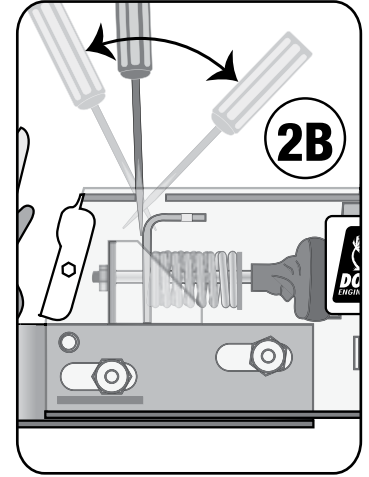
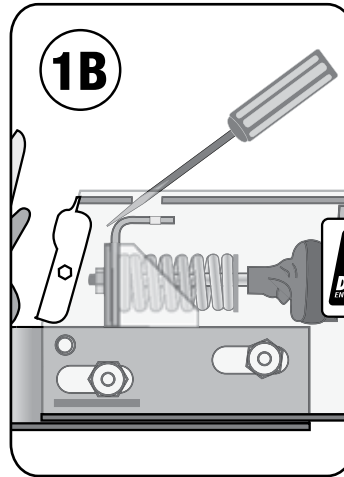
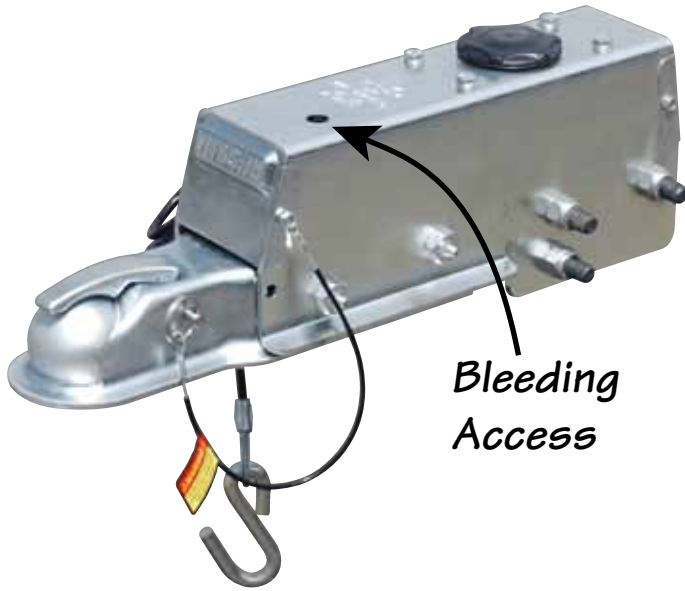

To pump master cylinder, insert a flat tip screwdriver into the round hole near the front of the actuator cover (See 1A). The screwdriver should be at the lowest angle possible to the actuator so that it slides in front of the e-stop bracket (See 1B). Screwdriver tip **MUST BE IN FRONT** of the e-stop bracket and **NOT** in the slot on the e-stop bracket (See 2A). Push the screwdriver forward and back to pump the master cylinder. (See 2B).

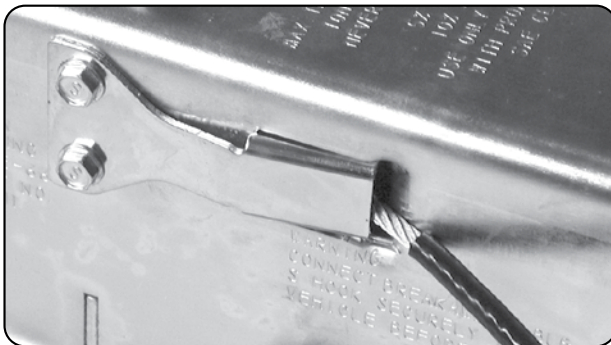

## Normal Operation

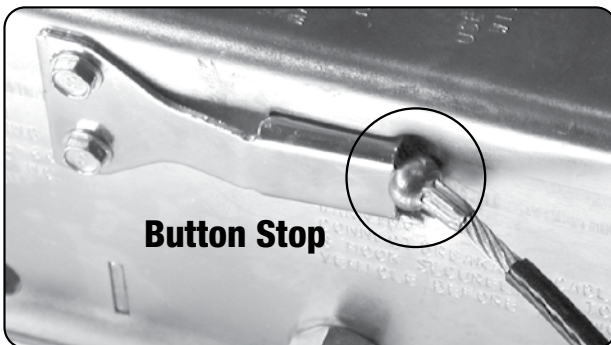

## Emergency Stop Position

**WARNING:** If button stop cable is showing **DO NOT TOW TRAILER**

Release emergency stop cable by prying spring out with a flat blade screw driver.